

MONTAJE / MONTAGE / MONTAGGIO / MONTAGEM / ASSEMBLY / BEDIENUNGSANLEITUNG

FR NOUS VOUS CONSEILLONS

- Poser les colis en position horizontale
- Classer et compter les éléments de montage et la quincaillerie
- Définir une zone de montage
- Suivre dans l'ordre les instructions de montage

ES TE ACONSEJAMOS

- Poner el paquete en posición horizontal
- Ordenar y contar las piezas y herrajes
- Habilita una zona para el montaje
- Sigue paso a paso las instrucciones de montaje

IT VI INFORMIAMO

- Porre la confezione in orizzontale
- Mettere in ordine e contare le minuterie metaliche
- Essere certi di avere spazio a per il montaggio
- Seguire passo passo le istruzioni

DE WIR RATEN IHNEN

- Legen Sie das Paket in eine horizontale Position, bevor Sie es öffnen
- Ordnen und zählen Sie die Teile und Beschläge
- Richten Sie einen Platz für die Montage ein
- Folgen Sie die Montageanleitung Schritt für Schritt

EN I ADVISE YOU

- Put the package in horizontal position
- Put in the order and count the pieces and iron fittings
- Take enough space for assembly
- Follow step by step the assembly instruction

FR Outils de montage nécessaires (not inclus dans le kit)

ES Las herramientas que necesitas (no incluidas en el kit)

IT Gli attrezzi che vi servono per il montaggio (non inclusi nella confezione)



DE Erforderliches Werkzeug (nicht im Bausatz enthalten)

EN The tools that you need for assembly (not included in the package)



FR Quincaillerie incluse dans le kit

ES Los herrajes que encontrarás en el kit

IT Accessori inclusi nella confezione

DE Die Beschläge, die Sie im Bausatz finden

EN The tools that you will find in the package

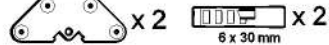
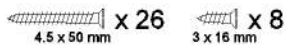

FR Pièces incluses dans le kit

ES Las piezas incluidas en el kit

IT Parti incluse nella confezione

DE Die im Bausatz enthalten Teile

EN The pieces included in the package

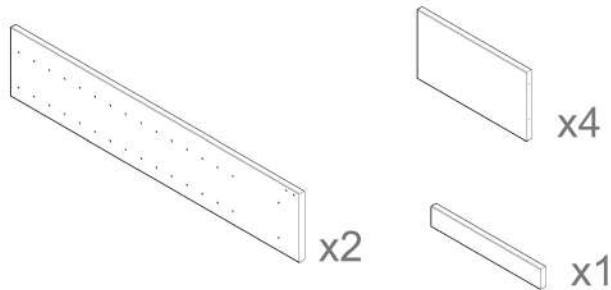

1

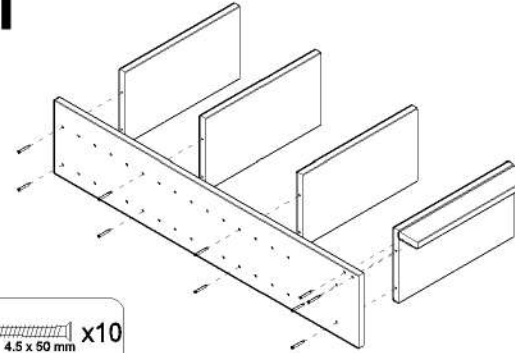

2

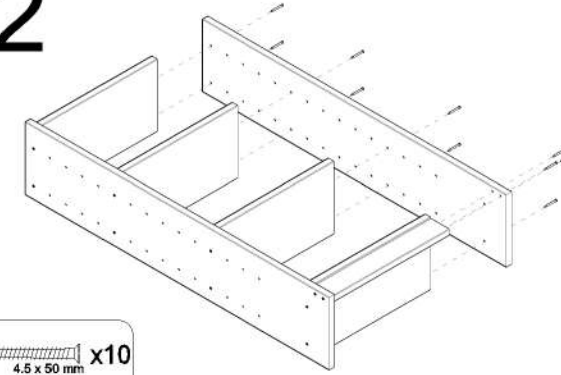

ref. GAL450.99

3

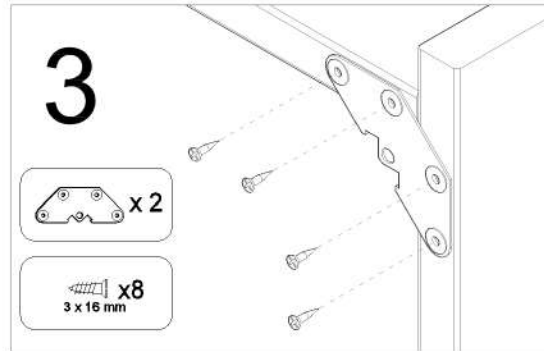

4

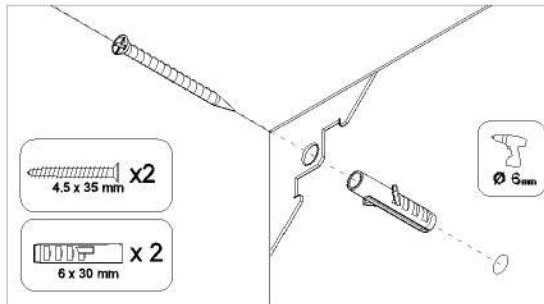

FR Pensez à donner ou recycler.



<https://quadransmedechets.fr>



ASTIGARRAGA
kit line



Olalde Area N°3
20730 Azpeitia (Gipuzkoa)
Tel. +34 943 814 261 - Fax +34 943 816 713
info@astikitline.es
www.astikitline.com

