

# MONTAJE / MONTAGE / MONTAGGIO / MONTAGEM / ASSEMBLY / BEDIENUNGSANLEITUNG

## ES TE ACONSEJAMOS

- Poner el paquete en posición horizontal.
- Ordenar y contar las piezas y herrajes.
- Habilitar una zona para el montaje.
- Sigue paso a paso las instrucciones de montaje.

## FR NOUS VOUS CONSEILLONS

- Poser les colis en position horizontale.
- Classer et compter les éléments de montage et la quincaillerie.
- Définir une zone de montage.
- Suivre dans l'ordre les instructions de montage.

## EN I ADVISE YOU

- Put the package in horizontal position.
- Put in the order and count the pieces and iron fittings.
- Take enough space for assembly.
- Follow step by step the assembly instruction.

## IT VI INFORMIAMO

- Porre la confezione in orizzontale.
- Mettere in ordine e contare le minuterie metalliche.
- Essere certi di avere spazio a sufficienza per il montaggio.
- Seguire passo passo le istruzioni.

ES - Las herramientas que necesitas (no incluidas en el kit) EN - The tools that you need for assembly (not included in the package)

FR - Outils de montage nécessaires (non inclus dans le kit)

IT - Gli attrezzi che vi servono per il montaggio (non inclusi nella confezione)

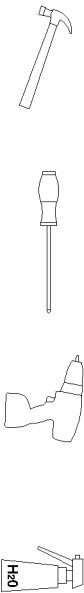

ES - Los herrajes que encontráis en el kit

FR - Quincaillerie incluse dans le kit

EN - The tools that you will find in the package

IT - Accessori incluso nella confezione.

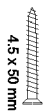
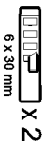

ES - Las piezas incluidas en el kit

FR - Pièces incluses dans le kit

EN - The pieces included in the package

IT - Parti incluse nella confezione

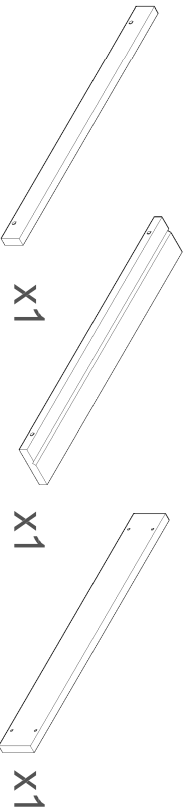

## ES USO DE LAS CLAVIAS PRE-ENCOLADAS

- Rellenar de agua la mitad del agujero con la ayuda de un pulverizador.
- Introducir la clavija.
- Rellenar de agua la mitad del segundo agujero.
- Introducir la otra parte de la clavija.
- ATTENZIONE! Colla ad azione rapida.

## EN USE OF PRE-GLUED PLUGS

- Fill half the hole with water with the help of a spray bottle.
- Insert the plug.
- Fill half the second hole with water.
- Insert the other part of the plug.
- ATTENTION! Fast acting glue.

## FR UTILISATION DE BOUCHONS PRÉ-COLLÉS

- Remplissez la moitié du trou avec ce'eau à l'aide d'un vaporisateur.
- Insérez la fiche.
- Remplissez la moitié du deuxième trou avec de l'eau.
- Insérez l'autre partie de la prise.
- ATTENTION! Colle à action rapide.

## IT UTILIZZO DI TAPPI PREINCOLLATI

- Riempire metà foro con acqua con l'aiuto di uno spruzzino.
- Inserire la spina.
- Riempire metà del secondo foro con acqua.
- Inserire l'altra parte della spina.
- ATTENZIONE! Colla ad azione rapida.

# 1

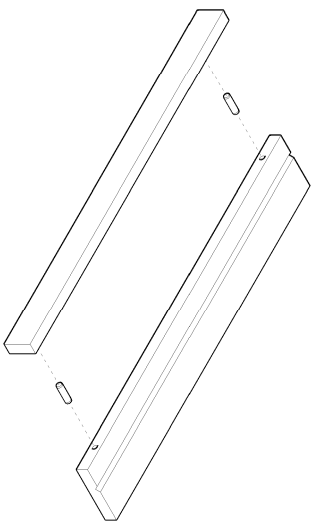

ES - Leer el uso de las clavijas pre encoladas.  
FR - Lire l'usage de la prise pré-collées.  
IT - Leggere l'uso del tasselli preincollati.

# 2

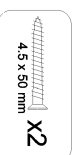
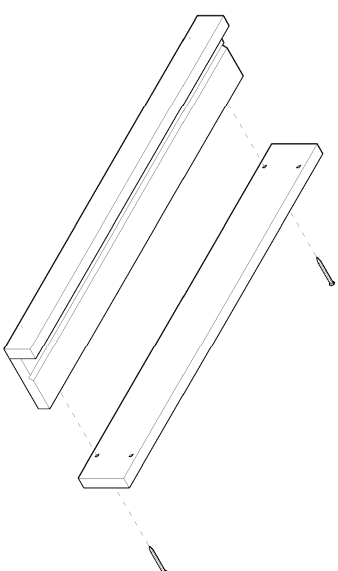

# 3

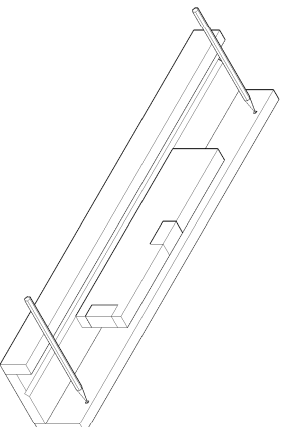

# 4



# 5

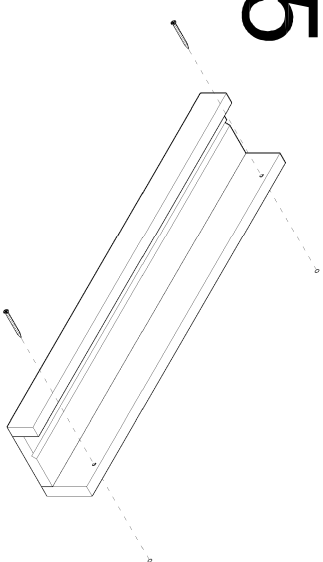
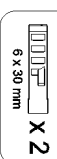

ref. EMSP60.99

## ASTIGARRAGA

*astigarraga*

E-20730 Astigarraga (Gipuzkoa)  
T. +34 945 814 281 If. +34 945 816 715  
astigarraga@kikttime.es  
www.astikttime.es

