

MONTAJE / MONTAGE / MONTAGGIO / MONTAGEM / ASSEMBLY / BEDIENUNGSANLEITUNG

ES TE ACONSEJAMOS

- Poner el paquete en posición horizontal.
- Ordenar y contar las piezas y herrajes.
- Habilita una zona para el montaje.
- Sigue paso a paso las instrucciones de montaje.

FR NOUS VOUS CONSEILLONS

- Poser les colis en position horizontale.
- Classer et compter les éléments de montage et la quincaillerie.
- Définir une zone de montage.
- Suivre dans l'ordre les instructions de montage.

EN I ADVISE YOU

- Put the package in horizontal position.
- Put in the order and count the pieces and iron fittings.
- Take enough space for assembly.
- Follow step by step the assembly instruction.

IT VI INFORMIAMO

- Porre la confezione in orizzontale.
- Mettere in ordine e contare le minuterie metaliche.
- Essere certi di avere spazio a per il montaggio.
- Seguire passo passo le istruzioni.

ES -Las herramientas que necesitas
(no incluidas en el kit)

FR -Outils de montage nécessaires
(not inclus dans le kit)

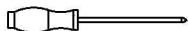

EN -The tools that you need for assembly
(not included in the package)

IT -Gli attrezzi che vi servono per il montaggio
(non inclusi nella confezione)



ES -Los herrajes que encontrarás en el kit

FR -Quincaillerie incluse dans le kit

EN -The tools that you will find in the package

IT -Accesori inclusi nella confezione.

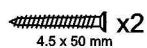

ES - Las piezas incluidas en el kit

FR - Pièces incluses dans le kit

EN - The pieces included in the package

IT - Parti incluse nella confezione

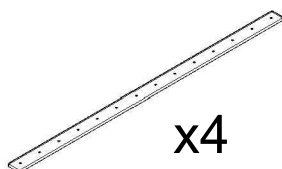
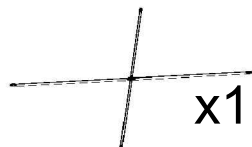
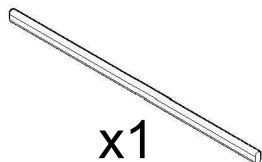
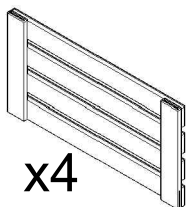

1

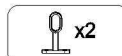
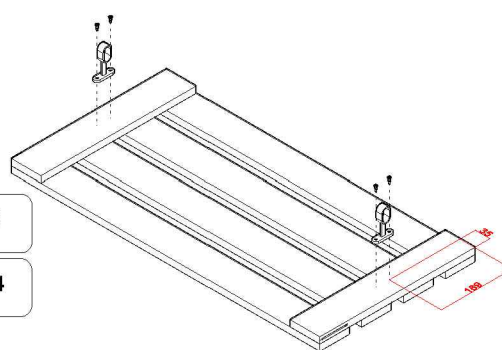

2

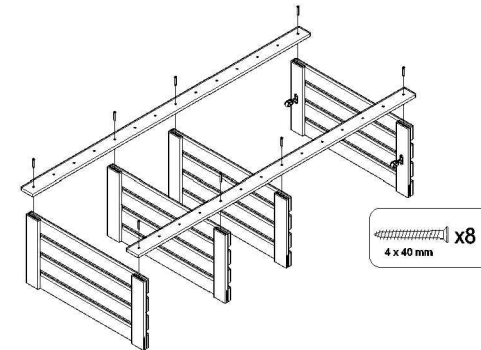

3

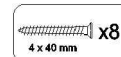
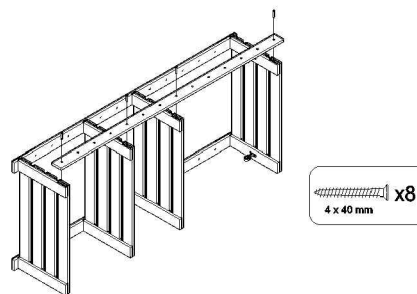

4

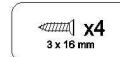
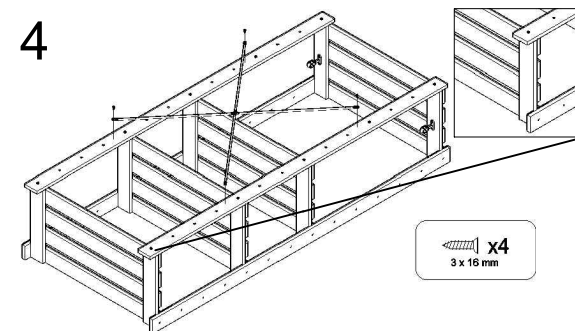

5

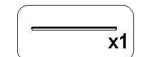
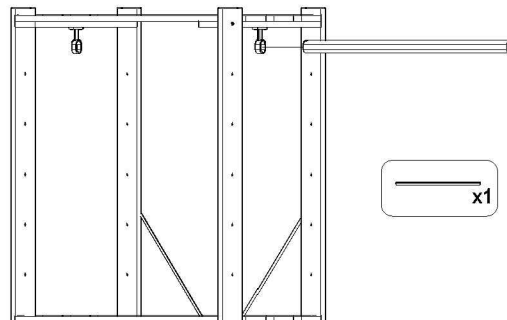

6

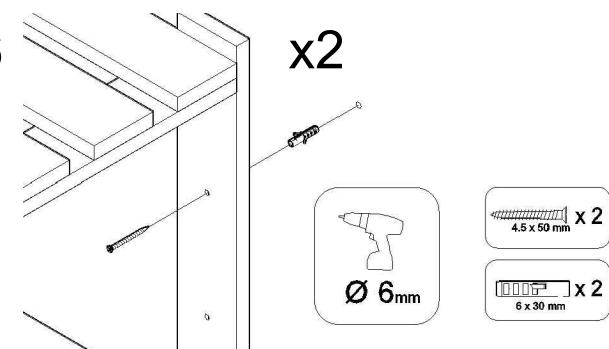

x2

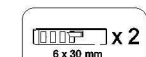
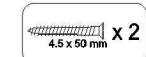
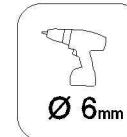

ref.EVPE40.99



ASTIGARRAGA



Olalde Area N°3
20730 Azpeltia (Gipuzkoa)
Tel. +34 943 814 261 - Fax +34 943 816 713
info@astikitline.es
www.astikitline.com

