

NVARSS.99

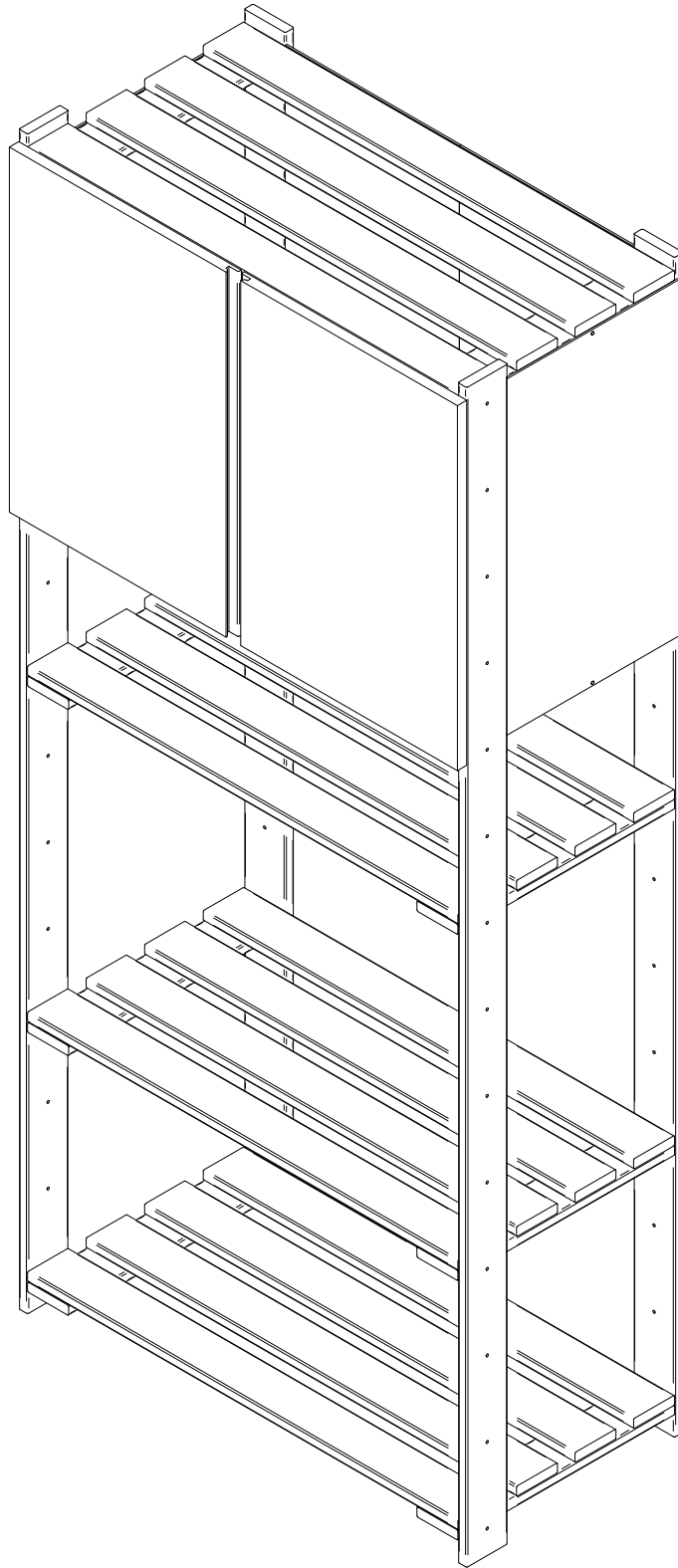

ASTIGARRAGA
kit line

FR MONTAGE ES MONTAJE IT MONTAGGIO
 DE BEDIENUNGSANLEITUNG EN ASSEMBLY

FR NOUS VOUS CONSEILLONS

- Poser les colis en position horizontale
- Classer et compter les éléments de montage et la quincaillerie
- Définir une zone de montage
- Suivre dans l'ordre les instructions de montage

DE WIR RATEN IHNEN

- Legen Sie das Paket in eine horizontale Position, bevor Sie es öffnen
- Ordnen und zählen Sie die Teile und Beschläge
- Richten Sie einen Platz für die Montage ein
- Folgen Sie die Montageanleitung Schritt für Schritt

ES TE ACONSEJAMOS

- Poner el paquete en posición horizontal
- Ordenar y contar las piezas y herrajes
- Habilita una zona para el montaje
- Sigue paso a paso las instrucciones de montaje

EN I ADVISE YOU

- Put the package in horizontal position
- Put in the order and count the pieces and iron fittings
- Take enough space for assembly
- Follow step by step the assembly instruction

IT VI INFORMIAMO

- Porre la confezione in orizzontale
- Mettere in ordine e contare le minuterie metaliche
- Essere certi di avere spazio a per il montaggio
- Seguire passo passo le istruzioni

FR Outils de montage nécessaires (not inclus dans le kit)

DE Erforderliches Werkzeug (nicht im Bausatz enthalten)

ES Las herramientas que necesitas (no incluidas en el kit)

EN The tools that you need for assembly (not included in the package)

IT Gli attrezzi che vi servono per il montaggio (non inclusi nella confezione)

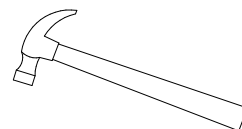
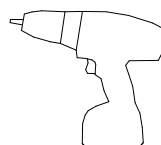
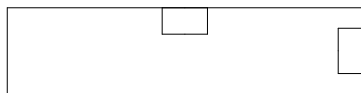

FR Quincaillerie incluse dans le kit

DE Die Beschläge, die Sie im Bausatz finden

ES Los herrajes que encontrarás en el kit

EN The tools that you will find in the package

IT Accessori inclusi nella confezione

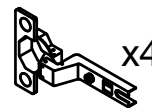
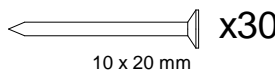
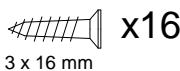
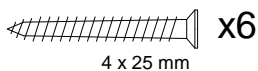
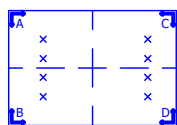

FR Pièces incluses dans le kit

DE Die im Bausatz enthalten Teile

ES Las piezas incluidas en el kit

EN The pieces included in the package

IT Parti incluse nella confezione

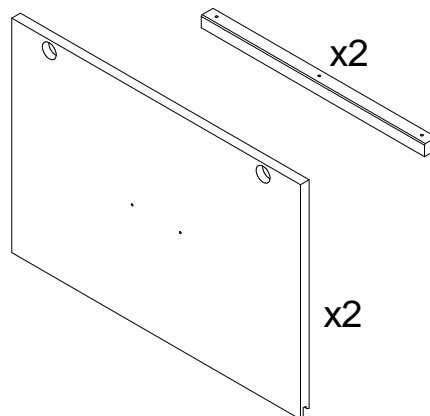
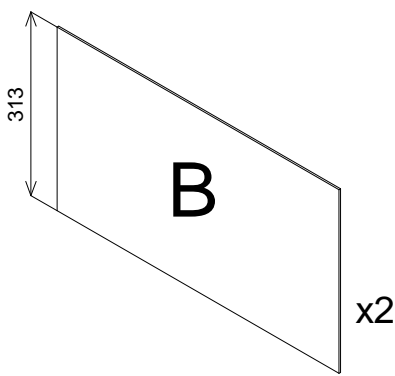
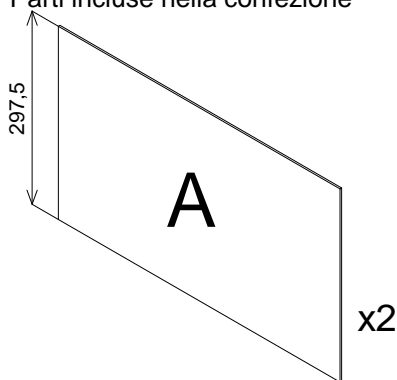

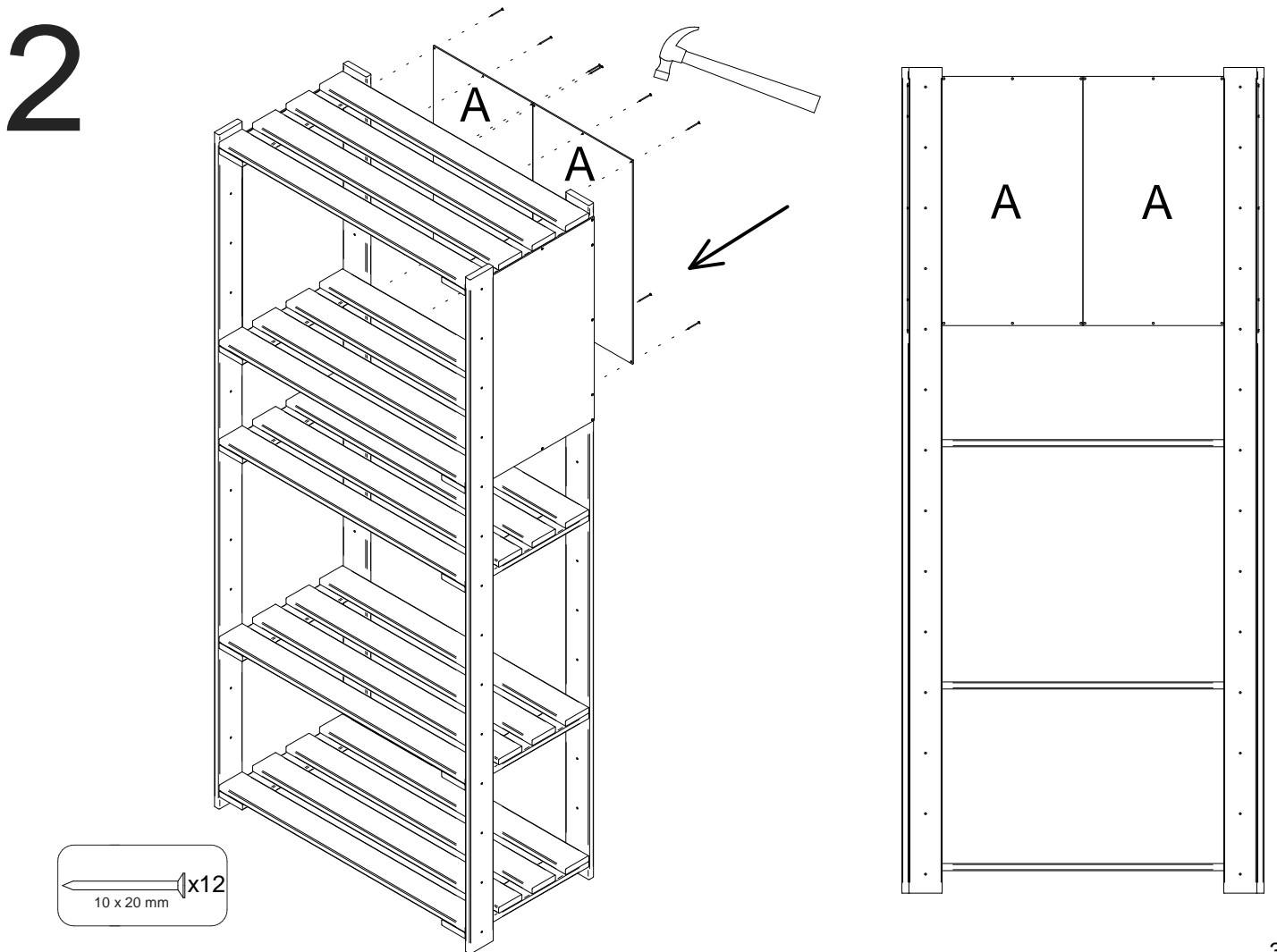
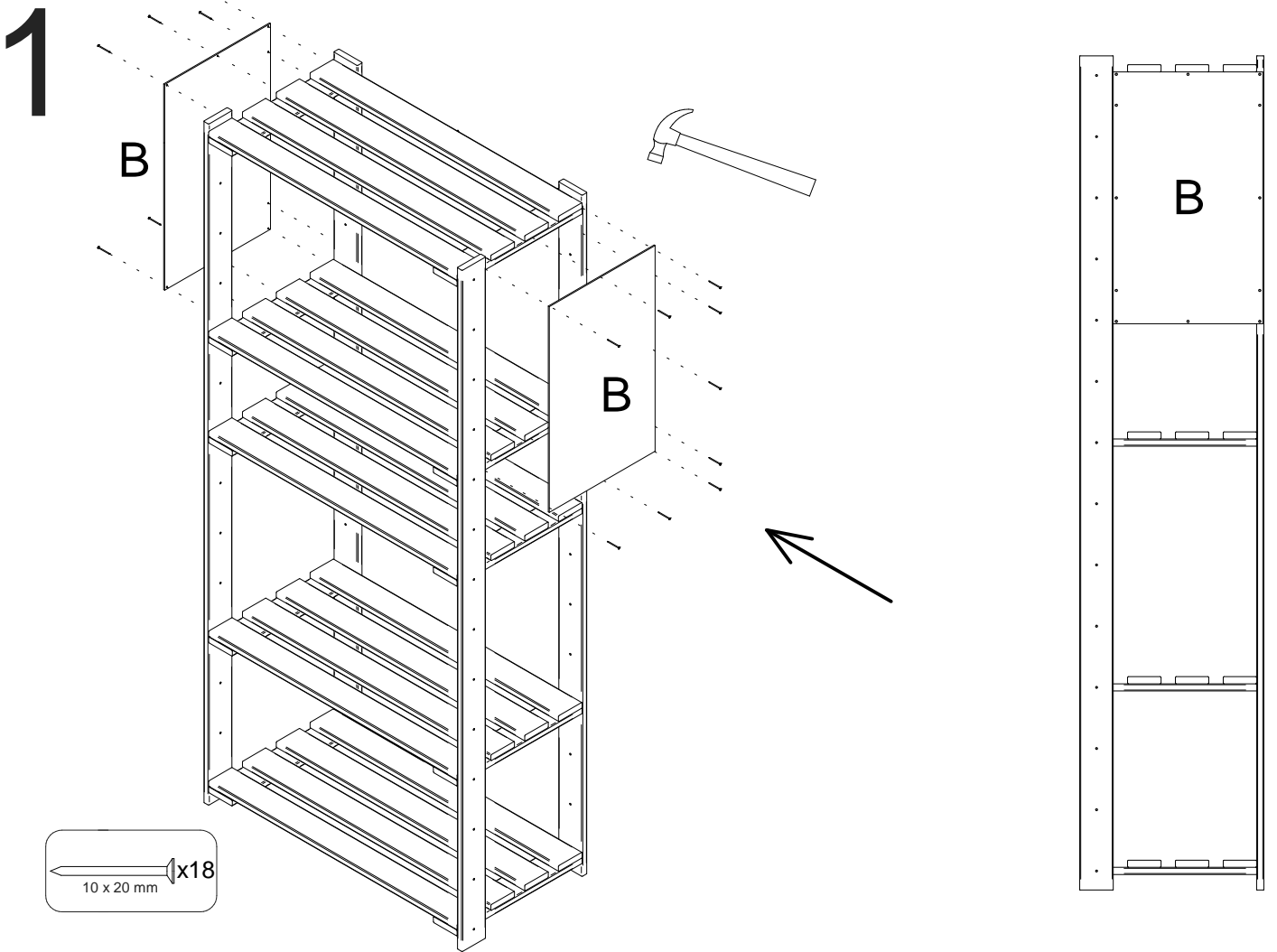

3

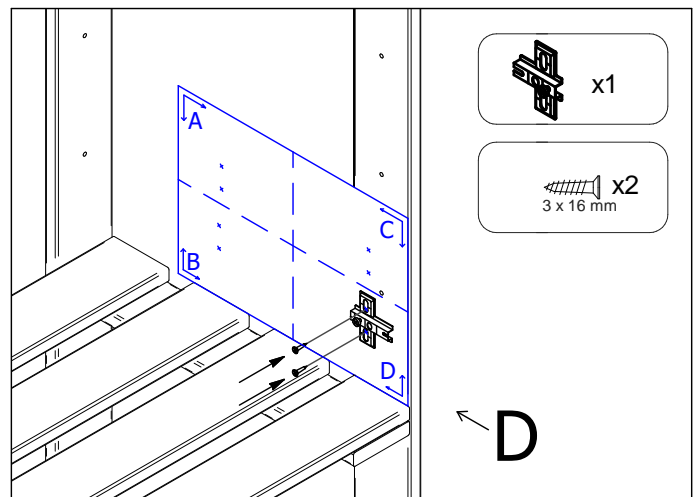
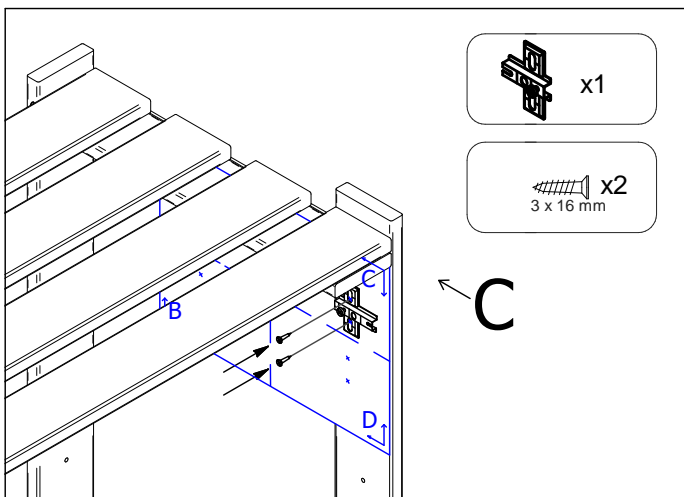
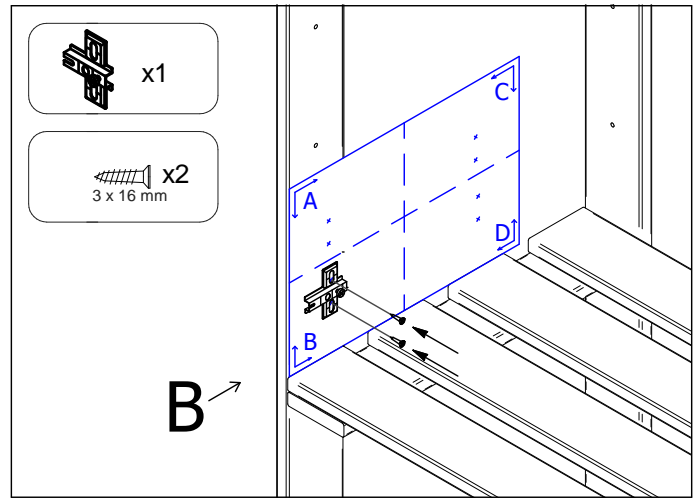
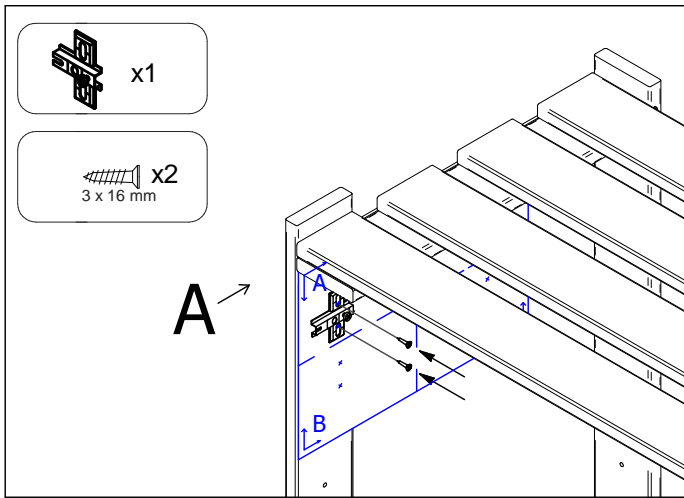
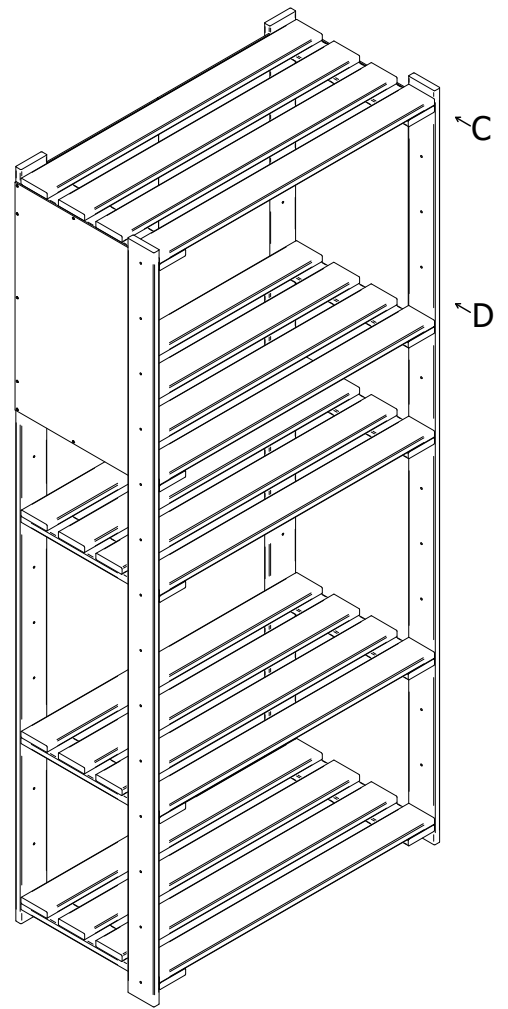
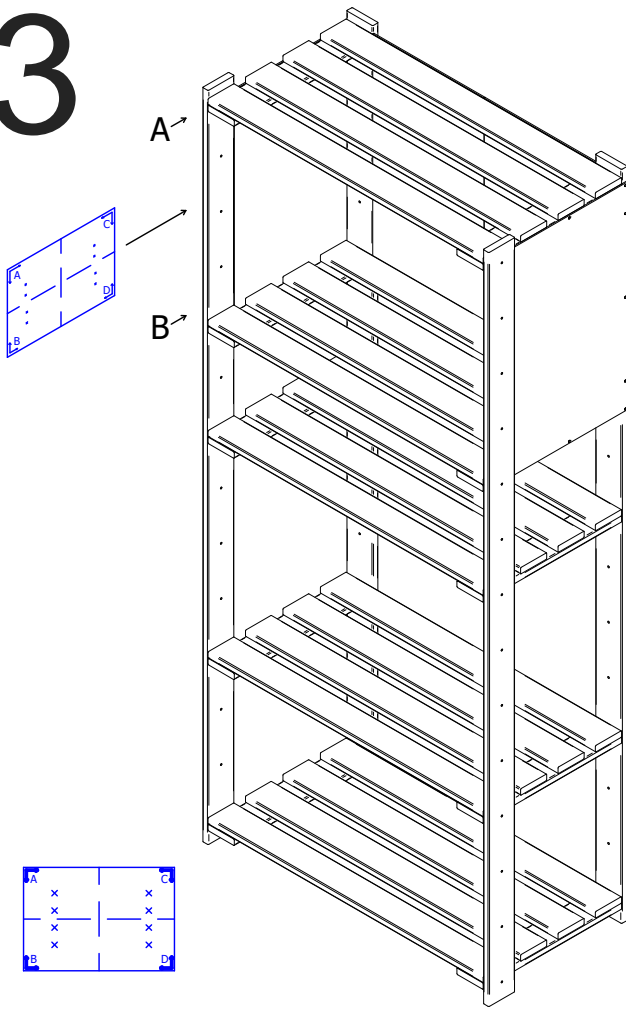

4

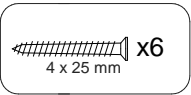
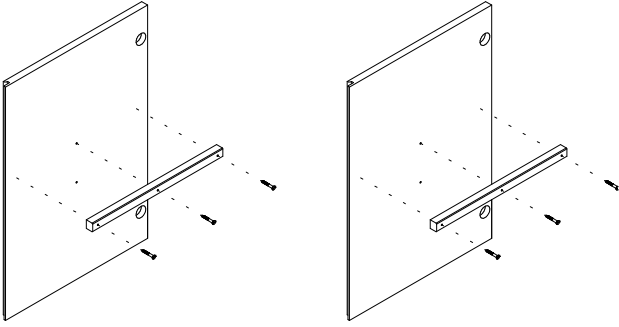

5

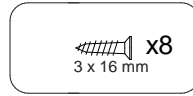
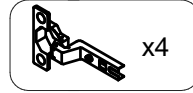
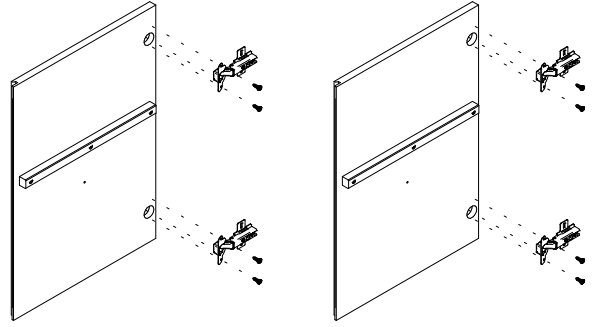

6

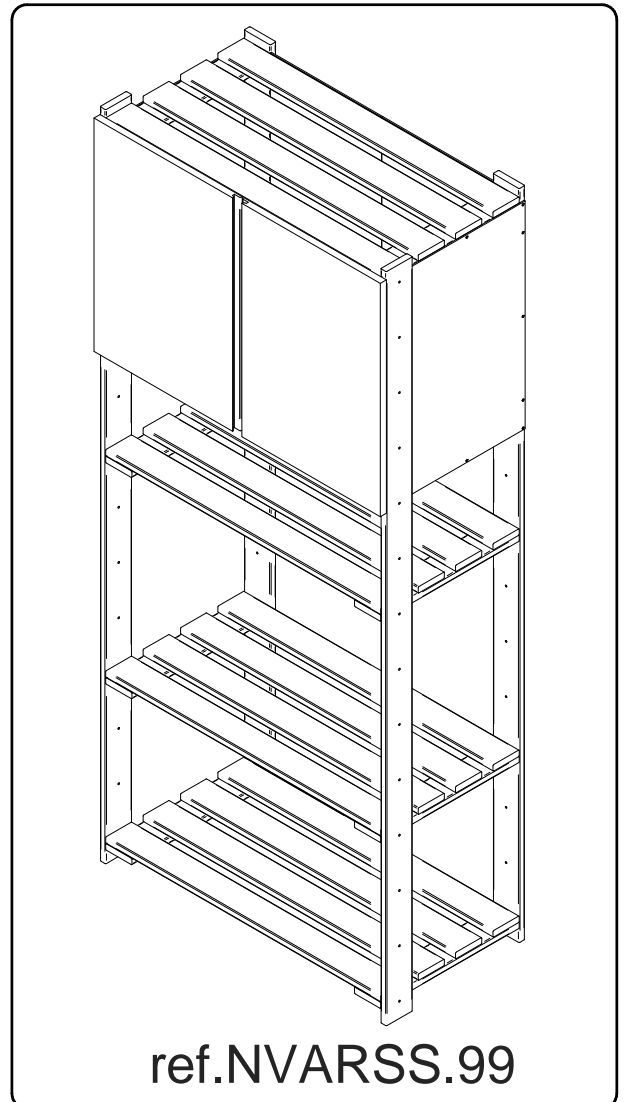
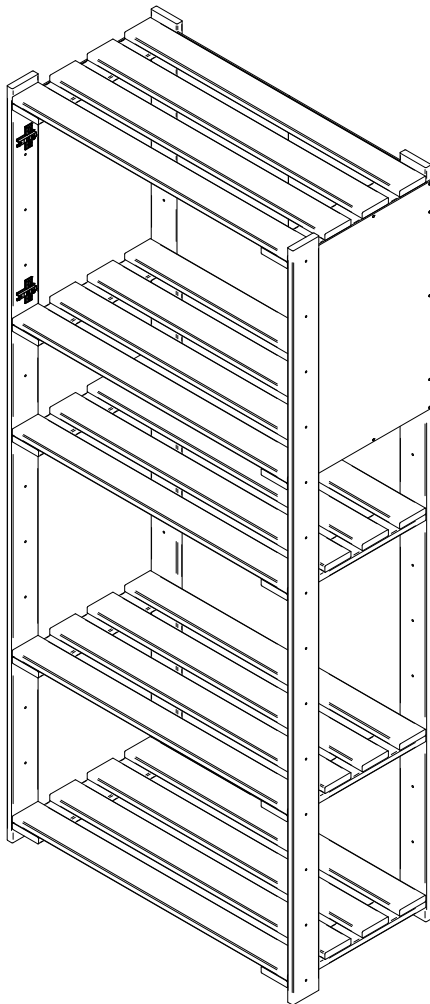
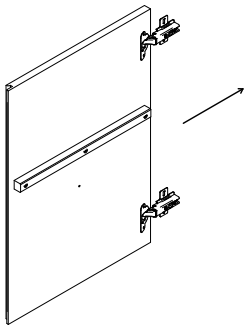

- Ⓣ RECOMMANDATIONS D'UTILISATION ET GARANTIE
- Ⓝ RECOMENDACIONES DE USO Y GARANTÍA
- Ⓜ RACCOMANDAZIONI PER L'USO E LA GARANZIA
- Ⓛ EMPFEHLUNGEN ZUR VERWENDUNG UND GARANTIE
- Ⓨ RECOMMENDATIONS FOR USE AND WARRANTY



ASTIGARRAGA

kit line



Oialde Area N°3
20730 Azpeitia (Gipuzkoa)
Tel. +34 943 814 261 - Fax +34 943 816 713
info@astikitline.es
www.astikitline.com

